

LOC	DIST	REVISIONS					
E	B	P	LTR	DESCRIPTION	DATE	DWN	APVD
		D		ECR-07-014829	21/06/07	AM	FWK

NOTES:

- ELECTRICAL DATA: CONTACT RESISTANCE: 10 mOhm MAX
INSULATION RESISTANCE: 100 MOhm MIN at 500VDC
CURRENT RATING: 5 AMPS FOR 3 AND 4 POSITIONS
BREAKDOWN VOLTAGE: 500 VAC MIN PER MINUTE
- ENVIRONMENTAL: OPERATING TEMPERATURE: -25°C TO +90°C
SEALING REQUIREMENTS: IP67
- PROD SPEC: 108-3641
- PACKAGING: 107-3334
- FOR TECHNICAL DATA REFER TO YOUR LOCAL TYCO ELECTRONICS SALES OFFICE.
- ALL DIMENSIONS ARE NOMINAL FOR REFERENCE ONLY UNLESS OTHERWISE STATED.

ITEM	DESCRIPTION	MATERIAL	FINISH/COLOUR	QUANTITY / ITEM	
				-1	-2
1	CONNECTOR HOUSING	GF NYLON	BLACK	1	1
2	PIN CONTACT	BRASS	0.15µm GOLD OVER NICKEL	3	4
3	CONNECTOR BODY	ZINC DIE CAST	2.5µm NICKEL PLATED	1	1
4	'O' RING	EPDM	BLACK	1	1
5	SCREW NUT	BRASS	2.5µm NICKEL PLATED	1	1

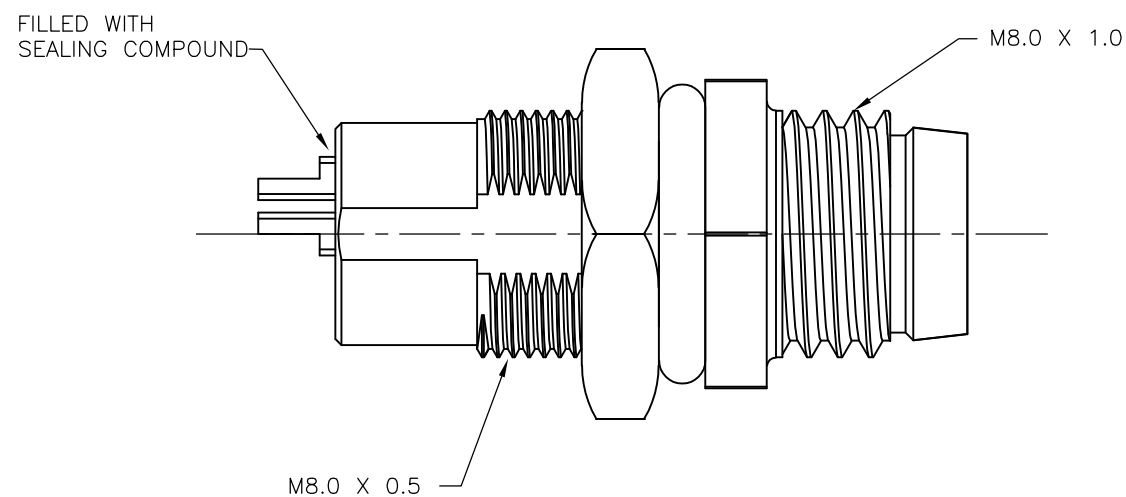
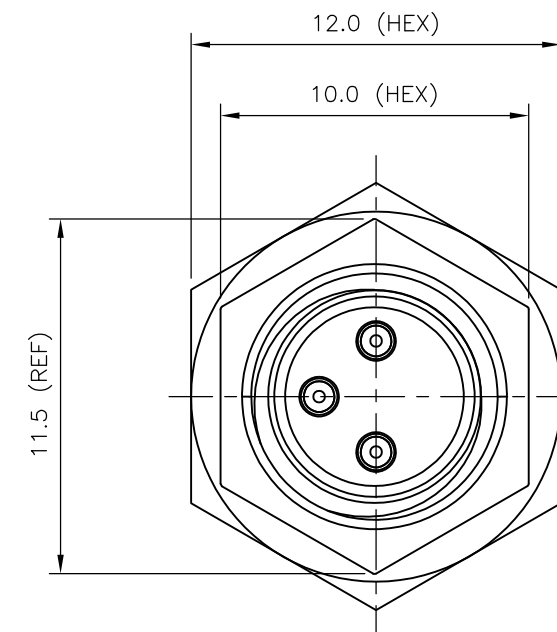
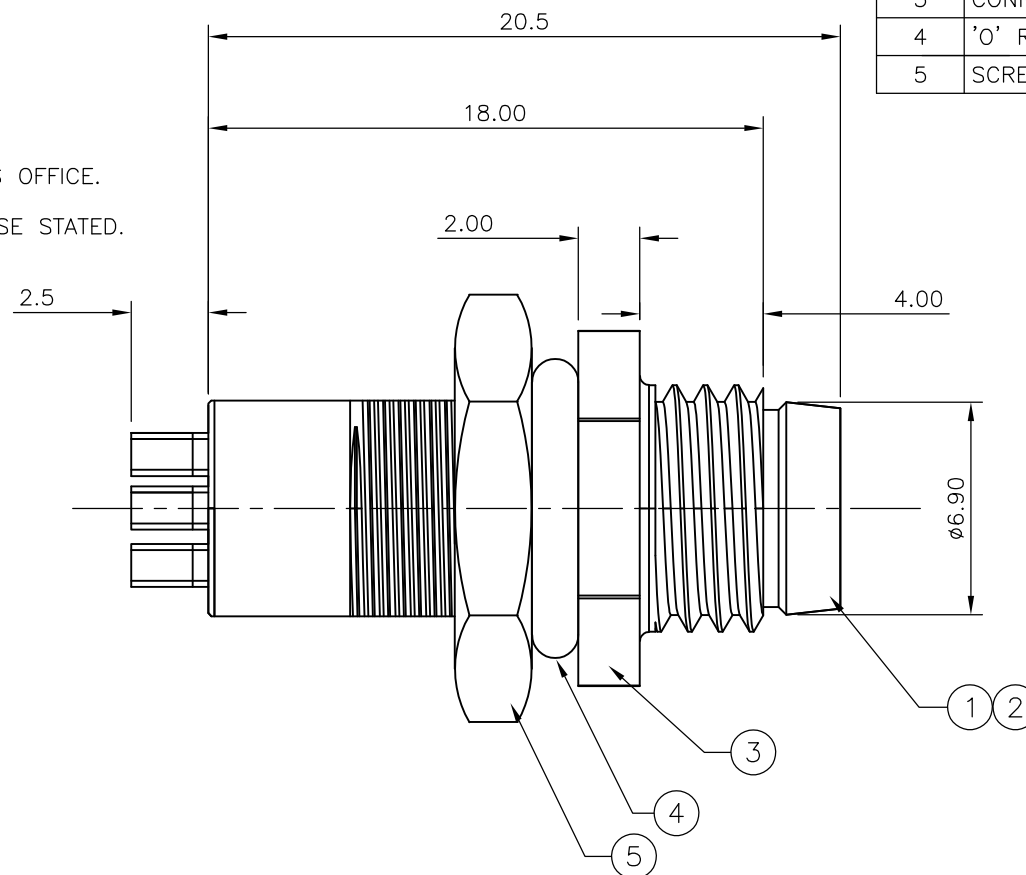
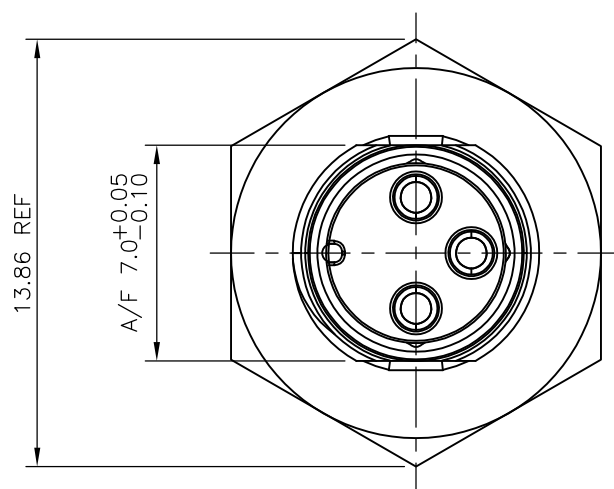

M8 METAL MALE PANEL MOUNT CONNECTOR, SOLDER, STRAIGHT, REAR (HEXAGONAL) MOUNTING	4	1838838-2
M8 METAL MALE PANEL MOUNT CONNECTOR, SOLDER, STRAIGHT, REAR (HEXAGONAL) MOUNTING	3	1838838-1
DESCRIPTION	NO. OF POS	PART NUMBER

THIS DRAWING IS A CONTROLLED DOCUMENT.		DWN A.Morey 21FEB07	Tyco Electronics Corporation Bideford, UK, EX39 4HE													
DIMENSIONS: mm		CHK F.Wheeler-King 22FEB07														
TOLERANCES UNLESS OTHERWISE SPECIFIED:		APVD F.Wheeler-King 22FEB07	NAME M8 METAL MALE PANEL MOUNT CONNECTOR, SOLDER, STRAIGHT, REAR (HEXAGONAL) MOUNTING													
<table border="1"> <tr><td>0 PLC</td><td>± -</td></tr> <tr><td>1 PLC</td><td>± -</td></tr> <tr><td>2 PLC</td><td>± -</td></tr> <tr><td>3 PLC</td><td>± -</td></tr> <tr><td>4 PLC</td><td>± -</td></tr> <tr><td>ANGLES</td><td>± -</td></tr> </table>		0 PLC	± -	1 PLC	± -	2 PLC	± -	3 PLC	± -	4 PLC	± -	ANGLES	± -	PRODUCT SPEC -	SIZE A3	
0 PLC	± -															
1 PLC	± -															
2 PLC	± -															
3 PLC	± -															
4 PLC	± -															
ANGLES	± -															
MATERIAL		APPLICATION SPEC -	CAGE CODE 00779	DRAWING NO G-1838838												
FINISH		WEIGHT -	RESTRICTED TO -													
CUSTOMER DRAWING			SCALE NTS	SHEET 1 OF 2												
			REV D													

THIS DRAWING IS UNPUBLISHED.

RELEASED FOR PUBLICATION 21FEB, 2007.

© COPYRIGHT 2007 BY TYCO ELECTRONICS CORPORATION. ALL RIGHTS RESERVED.

LOC	DIST	REVISIONS					
		P	LTR	DESCRIPTION	DATE	DWN	APVD
E	B		-	SEE SHEET 1	-	-	-

1838838-1

1838838-2

PIN ASSIGNMENTS
FRONT VIEW

PIN ASSIGNMENTS
FRONT VIEW

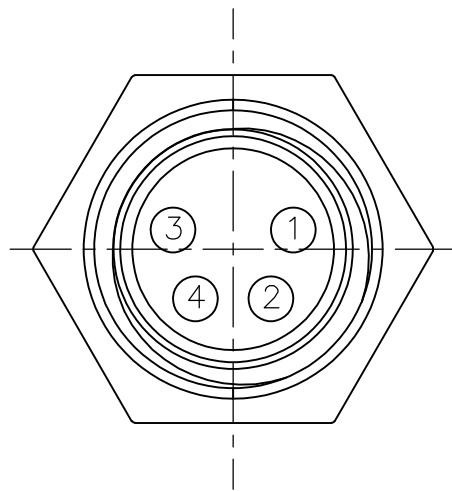
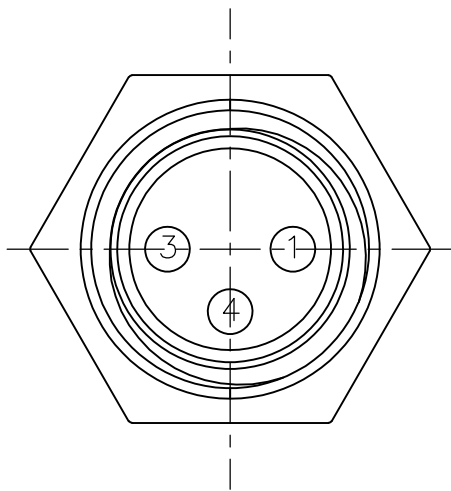

RECOMMENDED PANEL CUT-OUT
(MAX PANEL THICKNESS 3mm)

RECOMMENDED PANEL CUT-OUT
(MAX PANEL THICKNESS 3mm)

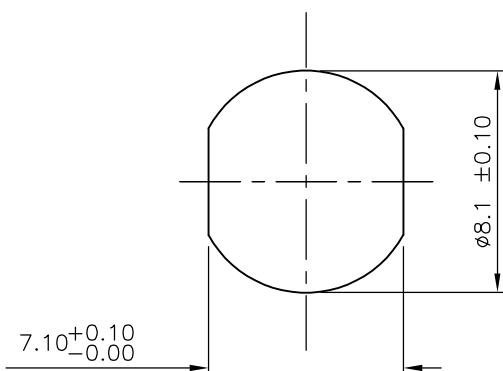
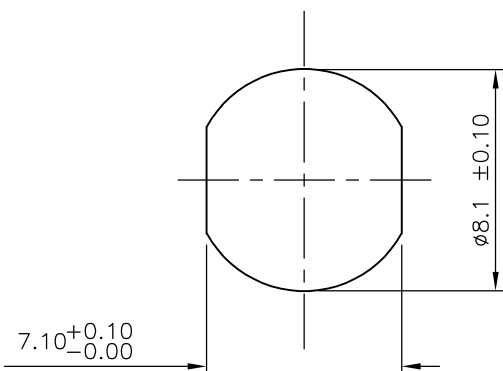

THIS DRAWING IS A CONTROLLED DOCUMENT.		DWN A.Morey 21FEB07	Tyco Electronics Corporation Bideford, UK, EX39 4HE		
DIMENSIONS: mm		CHK F.Wheeler-King 22FEB07	NAME M8 METAL MALE PANEL MOUNT CONNECTOR, SOLDER, STRAIGHT, REAR (HEXAGONAL) MOUNTING		
TOLERANCES UNLESS OTHERWISE SPECIFIED:		APVD F.Wheeler-King 22FEB07	PRODUCT SPEC		
<ul style="list-style-type: none"> 0 PLC ± - 1 PLC ± - 2 PLC ± - 3 PLC ± - 4 PLC ± - ANGLES ± - 		APPLICATION SPEC		RESTRICTED TO	
MATERIAL		WEIGHT	SIZE A3	CAGE CODE 00779	DRAWING NO C-1838838
FINISH		CUSTOMER DRAWING		SCALE NTS	SHEET 2 OF 2
				REV D	